

GUJARAT TECHNOLOGICAL UNIVERSITY**BE- SEMESTER-IV EXAMINATION – WINTER 2025****Subject Code:3141002****Date:13-11-2025****Subject Name:Analog Circuit Design****Time:02:30 PM TO 05:00 PM****Total Marks:70****Instructions:**

1. Attempt all questions.
2. Make suitable assumptions wherever necessary.
3. Figures to the right indicate full marks.
4. Simple and non-programmable scientific calculators are allowed.

| | MARKS |
|--|--------------|
| Q.1 (a) Define following terms. SVRR, Slew Rate, Input Offset Voltage. | 03 |
| (b) Draw and explain VTC of OP-AMP. | 04 |
| (c) Explain OP-AMP functionality as comparator. | 07 |
| Q.2 (a) Derive gain expression for inverting closed loop amplifier using OP-AMP. | 03 |
| (b) Explain subtractor using OP-AMP. | 04 |
| (c) Write and explain sample and hold amplifier using three OP-AMP. | 07 |
| OR | |
| (c) Explain peak detector circuit operation using OP-AMP. | 07 |
| Q.3 (a) Explain circuit made up of OP-AMP that does scaling of inputs. | 03 |
| (b) Explain band pass filter using OP-AMP. | 04 |
| (c) Explain 2 nd order low pass butter worth filter using OP-AMP with derivations. | 07 |
| OR | |
| Q.3 (a) Define following terms. Lock and Capture Range for PLL, Frequency Stability for Oscillators. | 03 |
| (b) Explain class B power amplifier. | 04 |
| (c) Draw and explain saw tooth wave generator using OP-AMP. | 07 |
| Q.4 (a) Explain I to V converter using OP-AMP. | 03 |
| (b) Explain phase shift oscillator using OP-AMP in detail. | 04 |
| (c) Explain CE short-circuit current gain with resistive load R_L . | 07 |
| OR | |
| Q.4 (a) Explain voltage limiter circuit using OP-AMP with suitable example. | 03 |
| (b) Draw and explain class AB power amplifier. | 04 |
| (c) Derive relationship between expressions of h-parameter and Hybrid – π model. | 07 |
| Q.5 (a) Design Monstable multivibrator for $T_P = 11$ millisecond, take $C = 0.01$ microferad. | 03 |
| (b) Write short note on voltage regulator. | 04 |
| (c) Explain applications of A-stable multivibrator using Timer IC. | 07 |
| OR | |
| Q.5 (a) Explain Schmitt trigger circuit using OP-AMP. | 03 |
| (b) Design A-stable multivibrator using IC 555 for $T_{on} = 50\%$ of T, take $F = 10$ KHz, $C = 0.01$ microferad. | 04 |
| (c) Explain block diagram of IC 555 timer. | 07 |

GUJARAT TECHNOLOGICAL UNIVERSITY

BE- SEMESTER-IV (NEW) EXAMINATION – WINTER 2024

Subject Code:3141002

Date:19-11-2024

Subject Name: Analog Circuit Design

Time:02:30 PM TO 05:00 PM

Total Marks:70

Instructions:

1. Attempt all questions.
2. Make suitable assumptions wherever necessary.
3. Figures to the right indicate full marks.
4. Simple and non-programmable scientific calculators are allowed.

MARKS

- Q.1 (a)** Why don't we see junction capacitances in h-parameter model? Why do they exist in hybrid-pi model? **03**
- (b)** **04**

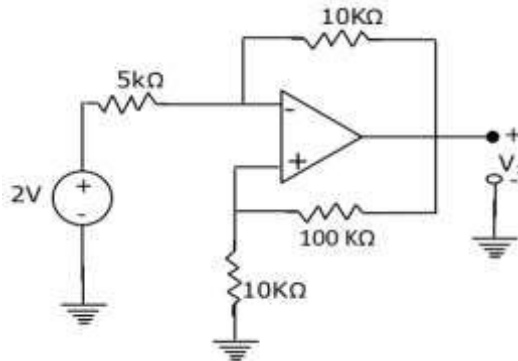

Determine the value of output voltage V_x for the above circuit.

- (c)** Derive an expression for transistor trans-conductance in CE configuration for hybrid-pi model. **07**
- Q.2 (a)** Define and briefly explain the term : Slew rate, for OP-AMPs **03**
- (b)** Explain the concept of virtual ground and discuss how it is different from actual ground. **04**
- (c)** Derive an expression for the input conductance for the hybrid- π model in CE configuration. **07**

OR

- (c)** Derive an expression for the base-spreading resistance for the hybrid- π model in CE configuration. **07**
- Q.3 (a)** State at least one use of Class A, Class B and Class C amplifiers. **03**
- (b)** Compare Voltage-series feedback amplifiers with current series feedback amplifiers. **04**
- (c)** Derive an expression for the frequency of oscillations for the Wien Bridge oscillator. **07**

OR

- Q.3 (a)** List the disadvantages of active RC filters. **03**
- (b)** Explain the Barkhausen criterion for oscillators. **04**
- (c)** Derive an expression for output resistance for current-series feedback amplifier using BJT. **07**

| | | |
|------------|---|-----------|
| Q.4 | (a) List the characteristics of an ideal OP-AMP. | 03 |
| | (b) Derive an expression for the output of the differentiator circuit using OP-AMP. | 04 |
| | (c) Describe the process of designing a second order active high pass filter with a suitable example. | 07 |
| OR | | |
| Q.4 | (a) Give full classification of Oscillators. | 03 |
| | (b) Discuss the factors affecting the stability of oscillators. | 04 |
| | (c) Describe the complete process of state variable filter design in details. | 07 |
| Q.5 | (a) State the applications of electronic filter circuits. | 03 |
| | (b) Derive an expression for the output of an OP-AMP as a non-inverting amplifier. | 04 |
| | (c) Draw the internal block diagram and explain the working of IC 555 based mono stable multi-vibrator | 07 |
| OR | | |
| Q.5 | (a) State the main factors governing the design of large signal (power) amplifiers. | 03 |
| | (b) Give classification of types of filters with their responses. | 04 |
| | (c) Explain the design of a LM 317 based voltage regulator with an example | 07 |

GUJARAT TECHNOLOGICAL UNIVERSITY**BE - SEMESTER-IV (NEW) EXAMINATION – WINTER 2023****Subject Code:3141002****Date:11-01-2024****Subject Name:Analog Circuit Design****Time:10:30 AM TO 01:00 PM****Total Marks:70****Instructions:**

1. Attempt all questions.
2. Make suitable assumptions wherever necessary.
3. Figures to the right indicate full marks.
4. Simple and non-programmable scientific calculators are allowed.

| | MARKS |
|--|-----------|
| Q.1 (a) List all the characteristics of an ideal OP-AMP. | 03 |
| (b) Explain how and why does trans-conductance varies with increasing $ I_c $, $ V_{CE} $ and Temperature at high frequency. | 04 |
| (c) You are given a set of components as follows: Resistors- 2.2 k Ω (2), 3.9k Ω (2), 4.7k Ω (2) a capacitor-0.1 μ F and an IC555.Design an astable multi-vibrator with free running frequency of approximately 1 kHz. Draw the final design with pin connections and values of each component chosen by you as your answer. Also, show all the calculations related to your design. | 07 |
| Q.2 (a) Give full forms of: CMRR, PSRR, PLL | 03 |
| (b) Explain the concept of virtual ground and discuss how it is different from actual ground. | 04 |
| (c) Derive an expression for the short circuit current gain for the hybrid- π model in CE configuration. | 07 |
| OR | |
| (c) Derive an expression for emitter diffusion capacitance in terms of base width, diffusion constant and trans-conductance for the hybrid- π model in CE configuration. | 07 |
| Q.3 (a) Give full forms: ADC, HPF, VCO | 03 |
| (b) Compare Class A and Class B amplifiers. | 04 |
| (c) Derive an expression for the frequency of oscillations for the Wein bridge oscillator. | 07 |
| OR | |
| Q.3 (a) What is an electronic filter? List all types of electronic filters. | 03 |
| (b) Compare current series feedback with current shunt feedback. | 04 |
| (c) A CE amplifier with an un-bypassed emitter resistance providing current series feedback to be designed for trans-conductance gain of -1 mA/V, voltage gain of -4 and a desensitivity of 50. If $R_s=1K\Omega$, $h_{fe}=150$ and $r_{bb'}$ is negligible, find (i) R_e , (ii) R_L ,(iii) R_{if} and (d) $I_{C(quietent)}$. | 07 |
| Q.4 (a) Define: Slew rate, Input bias current, Input offset current | 03 |
| (b) Explain the working of Class AB amplifier in brief. | 04 |
| (c) A Second Order Low Pass Filter is to be designed around a non-inverting op-amp with equal resistor and capacitor values in its cut-off frequency determining circuit. If the filters characteristics are given as: quality factor $Q = 5$, andcorner frequency $f_c = 159\text{Hz}$, design a suitable low pass filter. Assume $R=10\text{ k}\Omega$. | 07 |

OR

- Q.4** (a) In the Colpitts oscillator, $C_1=0.2 \mu\text{F}$ $C_2=0.02 \mu\text{F}$. If the frequency of oscillation required is 10 kHz, find the value of inductor. **03**
- (b) Explain Barkhausen criterion for oscillations. **04**
- (c) Describe the complete process of state variable filter design in details. **07**
- Q.5** (a) Give full forms: ECL, VCVS, GBP **03**
- (b) Give complete classification of oscillators. **04**
- (c) Derive the expressions for the voltage gain and input resistance with feedback for an emitter follower circuit. **07**
- OR**
- Q.5** (a) Calculate the frequency of oscillations for an RC phase shift oscillator given $R=10\text{K}\Omega$ and $C=0.1 \mu\text{F}$. **03**
- (b) For a non-inverting OP-AMP summing circuit with inputs of 1V, 2V and 3V, respectively, $R_f=2\text{K}\Omega$ and $R_{in}=1\text{K}\Omega$. Determine output voltage. **04**
- (c) Design an adjustable voltage regulator using LM317 to satisfy the following specifications: **07**
 Output Voltage=5 to 12 V, Output current=1.0 A. $I_{ADJ}=100 \mu\text{A}$.
 Assume $R_1=240\Omega$.

GUJARAT TECHNOLOGICAL UNIVERSITY**BE - SEMESTER-IV(NEW) EXAMINATION – WINTER 2022****Subject Code:3141002****Date:13-12-2022****Subject Name:Analog Circuit Design****Time:10:30 AM TO 01:00 PM****Total Marks:70****Instructions:**

1. Attempt all questions.
2. Make suitable assumptions wherever necessary.
3. Figures to the right indicate full marks.
4. Simple and non-programmable scientific calculators are allowed.

| | MARKS |
|--|--------------|
| Q.1 (a) Define following terms. CMRR, PSRR, Slew Rate. | 03 |
| (b) Explain Voltage Transfer Curve of OP-AMP. | 04 |
| (c) Write and explain differential amplifier using two OP-AMP. | 07 |
| Q.2 (a) List OP-AMP's ideal characteristics. | 03 |
| (b) Derive gain expression for voltage series F/B amplifier using OP-AMP. | 04 |
| (c) Explain inverting differentiator circuit using OP-AMP. | 07 |
| OR | |
| (c) Explain instrumentation amplifier circuit operation using OP-AMP. | 07 |
| Q.3 (a) Explain circuit made up of OP-AMP that does average of inputs. | 03 |
| (b) Explain Schmitt trigger circuit using OP-AMP. | 04 |
| (c) Explain 2 nd order low pass filter using OP-AMP with derivations. | 07 |
| OR | |
| Q.3 (a) Define following terms. Lock Range for PLL, Capture Range for PLL, Frequency Stability for Oscillators. | 03 |
| (b) Explain class B power amplifier. | 04 |
| (c) Draw and explain triangular wave generator using OP-AMP. | 07 |
| Q.4 (a) Explain floating load V to I converter using OP-AMP. | 03 |
| (b) Explain phase shift oscillator using OP-AMP in detail. | 04 |
| (c) Explain CE short-circuit current gain with resistive load R_L . | 07 |
| OR | |
| Q.4 (a) Explain sample hold circuit using OP-AMP. | 03 |
| (b) Draw and explain class AB power amplifier. | 04 |
| (c) Derive expression for trans-conductance g_m in Hybrid – Π model. | 07 |
| Q.5 (a) Design Monstable multivibrator using timer IC for $T_P = 11$ millisecond, take $C = 0.1$ microferad. | 03 |
| (b) Write short note on voltage regulator. | 04 |
| (c) Explain A-stable multivibrator using timer IC. | 07 |
| OR | |
| Q.5 (a) Explain half wave rectifier circuit using OP-AMP. | 03 |
| (b) Design A-stable multivibrator using IC 555 for $T_{on} = 75\%$ of T , take $F = 1$ KHZ, $C = 0.1$ microferad. | 04 |
| (c) Explain monostable multivibrator using IC 555. | 07 |
