

GUJARAT TECHNOLOGICAL UNIVERSITY

BE- SEMESTER-VI EXAMINATION – WINTER 2025

Subject Code:3161917

Date:29-11-2025

Subject Name:Computer Aided Manufacturing

Time:02:30 PM TO 05:00 PM

Total Marks:70

Instructions:

1. Attempt all questions.
2. Make suitable assumptions wherever necessary.
3. Figures to the right indicate full marks.
4. Simple and non-programmable scientific calculators are allowed.

		MARKS
Q.1	(a) Explain accuracy and repeatability.	03
	(b) Name three techniques of interpolation.	04
	(c) Give specifications of a machining centre.	07
Q.2	(a) What are canned cycles and sub- routines.	03
	(b) What are the essential elements of a PLC system?	04
	(c) Differentiate <ol style="list-style-type: none"> (i) AC servomotors & DC servomotors. (ii) CNC Lathe & CNC Turning centre 	07
	OR	
Q.3	(c) Write a NC part program using G and M code, to cut a slot for the component, shown in fig. by using an end mill of 10 mm diameter. Assume suitable data for machining parameters.	07

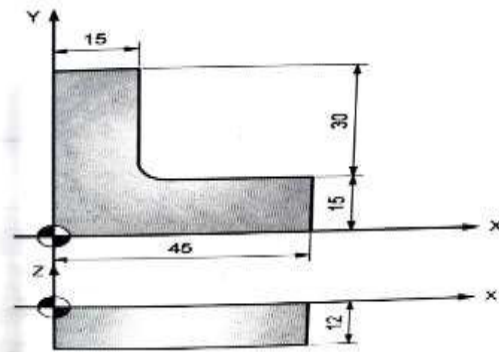

Q.3	(a) What are the various activities of a manufacturing plant which can be carried out through computer control?	03
	(b) Enlist robot programming method. Explain any one in detail.	04
	(c) Explain different end effectors used in ROBOTS and state their applications.	07
	OR	
Q.3	(a) Discuss the main elements of CIM systems.	03
	(b) Give technical specification of a ROBOT.	04
	(c) What are SCARA configuration ROBOT? Explain its work envelope.	07
Q.4	(a) What is the need for computer aided process planning? What are its advantages?	03
	(b) Define Part Families. Explain different attributes used for family formation.	04
	(c) Classify a component using either OPITZ or MICLASS system.	07

OR

- Q.4** (a) Describe the structure of a process plan. **03**
(b) What are the major modules of a process planning software and the databases required? **04**
(c) Compare variant and generative process planning methodologies. **07**

- Q.5** (a) Explain different types of AGVs with their advantages . **03**
(b) Describe with neat sketch AS/RS system used in FMS **04**
(c) Explain different types of FMS layout with neat sketch. **07**

OR

- Q.5** (a) What is the significance of bill of materials? **03**
(b) Explain the concept of expert system used in manufacturing. **04**
(c) Discuss the Just In Time manufacturing. **07**

GUJARAT TECHNOLOGICAL UNIVERSITY**BE- SEMESTER-VI (NEW) EXAMINATION – WINTER 2024****Subject Code:3161917****Date:12-12-2024****Subject Name: Computer Aided Manufacturing****Time:02:30 PM TO 05:00 PM****Total Marks:70****Instructions:**

1. Attempt all questions.
2. Make suitable assumptions wherever necessary.
3. Figures to the right indicate full marks.
4. Simple and non-programmable scientific calculators are allowed.

- Q.1** (a) Define Computer-Aided Manufacturing (CAM). What are its primary objectives? **03**
 (b) Evaluate the advantages of using PLCs over traditional hardwired control systems in terms of programming flexibility. **04**
 (c) Identify the major components of a CIM system. Analyze the impact of CIM on production planning and control. **07**
- Q.2** (a) Define NC and CNC technology. What are the differences between them? **03**
 (b) Explain the role of sensors and actuators in a CNC system. **04**
 (c) Write a simple part program to perform a drilling operation using a CNC machine. **07**
- OR**
- (c) Explain working of recirculating ball screw. How does a recirculating ball screw contribute to the precision and efficiency of CNC machines? **07**
- Q.3** (a) What is a Flexible Manufacturing System (FMS)? List the key components of an FMS. **03**
 (b) Explain the concept of cellular manufacturing and how it differs from traditional batch production. **04**
 (c) Explain the working principle of AS/RS and how it benefits warehouse operations. **07**
- OR**
- Q.3** (a) List the primary objectives of implementing an FMS. **03**
 (b) Explain the importance of layout design in the efficiency of an FMS. **04**
 (c) Define Automated Guided Vehicles (AGVs). Compare the advantages and disadvantages of AGVs versus traditional material handling methods. **07**
- Q.4** (a) List the main functions of PPC in a manufacturing system. **03**
 (b) Identify the key benefits of implementing Group Technology in manufacturing. **04**
 (c) Define Computer-Aided Process Planning (CAPP). Explain the difference between variant and generative CAPP systems. **07**
- OR**
- Q.4** (a) Explain Enterprise Resource Planning (ERP). **03**
 (b) List the steps involved in the rank order clustering method for cell design. **04**
 (c) Compare the OPITZ and PFA coding systems in terms of complexity and application with suitable example. **07**
- Q.5** (a) Explain the benefits of using robots in manufacturing compared to manual labor. **03**
 (b) Discuss the role of JIT in inventory management and cost reduction. **04**
 (c) Explain various physical configuration of robot with example. **07**
- OR**
- Q.5** (a) Explain the difference between forward kinematics and inverse kinematics in robotic motion planning. **03**
 (b) Describe key components of an expert system. **04**
 (c) Define actuators and transducers in the context of robotics. Describe the role of transducers in robotic sensing and feedback systems. **07**

GUJARAT TECHNOLOGICAL UNIVERSITY

BE - SEMESTER-VI (NEW) EXAMINATION – WINTER 2023

Subject Code:3161917

Date:18-12-2023

Subject Name: Computer Aided Manufacturing

Time: 02:30 PM TO 05:00 PM

Total Marks:70

Instructions:

1. Attempt all questions.
2. Make suitable assumptions wherever necessary.
3. Figures to the right indicate full marks.
4. Simple and non-programmable scientific calculators are allowed.

		MARKS
Q.1	(a) Explain the advantages of Computer Aided Manufacturing.	03
	(b) Define PLC. Brief about the relay device components used in it.	04
	(c) Classify NC machine based on programming method, feedback control and tool motion control system.	07
Q.2	(a) Explain tool management system in FMS	03
	(b) What are the components of machine vision system in robotics?	04
	(c) Prepare CNC milling part program to cut the outside of the profile for the figure 1. (Use machining parameter as spindle speed 2000 RPM and Feed 150 mm per min, The thickness of plate is 12 mm)	07

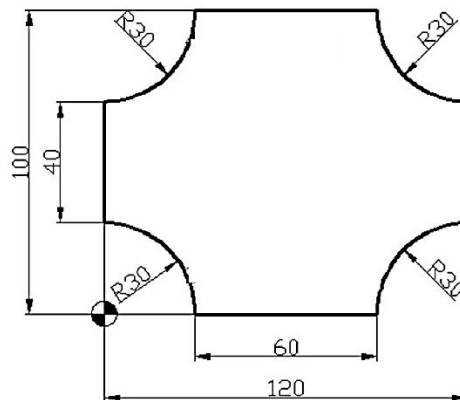

Figure 1

OR

- | | |
|---|-----------|
| <p>(c) Prepare CNC turning part program for the figure 2. (Use stock removal cycle G71 first with depth of cut 0.5 mm and 0.1 mm finishing allowance then use G70 for finishing operation with Spindle speed 700RPM and Feed 0.5 mm per revolution)</p> | 07 |
|---|-----------|

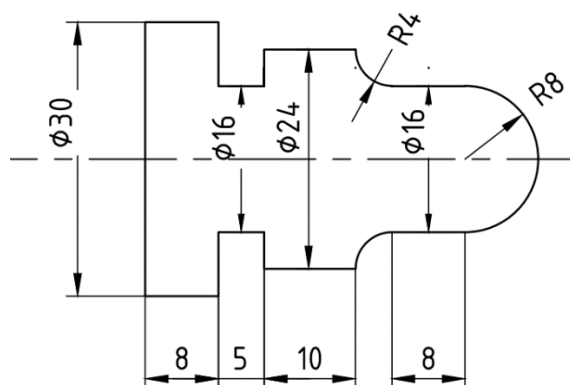

Figure 2

- Q.3 (a)** Define Part Families. Explain different attributes used for family formation. **03**
- (b)** List the robot configurations and explain any one with neat sketch. **04**
- (c)** What is computer aided process planning? Explain benefits over traditional process planning. **07**
- OR**
- Q.3 (a)** List the method to make part families. Explain any one in brief **03**
- (b)** Describe various sensors used in robot technology. **04**
- (c)** Why is part classification and coding required in GT. Explain OPTIZ system of coding. **07**
- Q.4 (a)** Describe the terms with reference to Robot: 1. Payload, 2. Work envelop 3. Manipulator **03**
- (b)** What are the steps needed to develop the flexible manufacturing cells from scratch? **04**
- (c)** Explain different types of FMS layout with neat sketch. **07**
- OR**
- Q.4 (a)** What are the various types of motion control possible in robots? **03**
- (b)** Describe with neat sketch AS/RS system used in FMS **04**
- (c)** Explain different types of AGVs with their advantages and limitations. **07**
- Q.5 (a)** What is an ERP System and why is it used? **03**
- (b)** Explain expert system. **04**
- (c)** Explain MRP-I and MRP-II. **07**
- OR**
- Q.5 (a)** What are the steps to successful ERP implementation? **03**
- (b)** Explain in brief about the JIT philosophy. **04**
- (c)** Elaborate on computer integrated production management system with neat flow chart. **07**

GUJARAT TECHNOLOGICAL UNIVERSITY**BE - SEMESTER-VI(NEW) EXAMINATION – WINTER 2022****Subject Code:3161917****Date:20-12-2022****Subject Name:Computer Aided Manufacturing****Time:02:30 PM TO 05:00 PM****Total Marks:70****Instructions:**

1. Attempt all questions.
2. Make suitable assumptions wherever necessary.
3. Figures to the right indicate full marks.
4. Simple and non-programmable scientific calculators are allowed.

- | | Marks |
|--|--------------|
| Q.1 (a) Explain the benefits of Computer Aided Manufacturing. | 03 |
| (b) Explain the PLC architecture using neat sketch. | 04 |
| (c) Draw and explain the CIM wheel to understand basic functions. | 07 |
| Q.2 (a) Draw and explain axis designation for vertical axis milling machine. | 03 |
| (b) What are the different elements of an industrial robot? | 04 |
| (c) Illustrate the use of canned cycle and subprograms with example in case of manual part programming. | 07 |
| OR | |
| (c) Write a manual part program for drilling and milling of a component with 10mm thickness as shown in Fig. 1. Consider 10 mm diameter milling cutter and necessary drill size for drilling operation. Assume suitable spindle speed and feed for drilling and milling operation. | 07 |

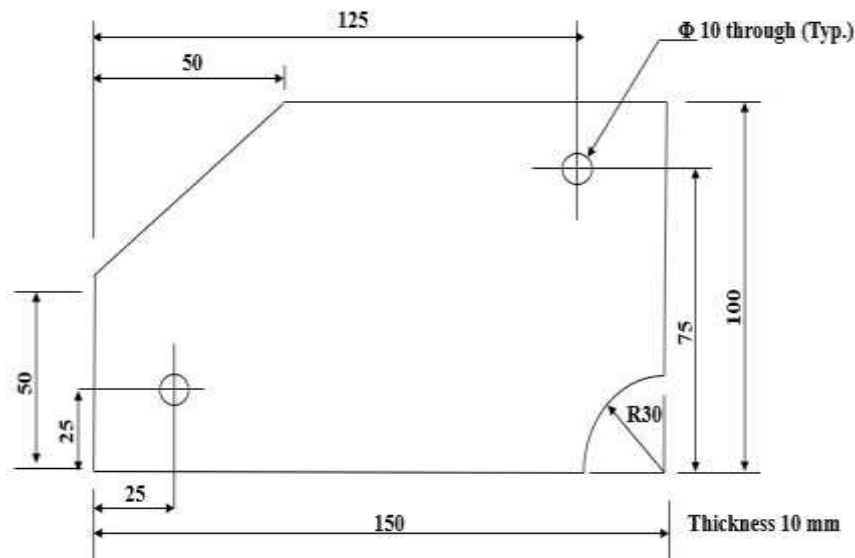
**Fig.1**

- | | |
|---|-----------|
| Q.3 (a) Define Part Families. Explain different attributes used for family formation. | 03 |
| (b) Write a short note on: Automated guided vehicle associated with FMS | 04 |
| (c) Discuss the three basic code structures used in classification and coding for group technology. | 07 |
| OR | |
| Q.3 (a) What is CAPP? Explain its benefits over traditional process planning. | 03 |
| (b) Write a short note on: Tool monitoring system used in FMS | 04 |
| (c) Discuss various codes used for GT. Explain the digits used in Opitz code. | 07 |
| Q.4 (a) Explain the basic components of FMS | 03 |

- (b) List the robot configurations and explain any one with neat sketch. **04**
(c) Write a note on: Different types of flexibility required in an FMS. **07**

OR

- Q.4** (a) Describe with neat sketch AS/RS system used in FMS **03**
(b) What are SCARA configuration robot? Explain its work envelope. **04**
(c) Explain different types of FMS layouts with neat diagram. **07**

- Q.5** (a) Describe various sensors used in robot technology. **03**
(b) Explain in brief about the JIT philosophy. **04**
(c) Elaborate on computer integrated production management system with neat flow chart. **07**

OR

- Q.5** (a) What are the various factors which influence the selection of end effector of a robot. **03**
(b) Explain the concept of expert system used in manufacturing. **04**
(c) Elaborate on JIT production systems. How are these usefully associated with FMS? **07**
