

GUJARAT TECHNOLOGICAL UNIVERSITY

BE-4 SEMESTER – OLD PAPER – S22 TO W25 – QUESTION BANK SOLUTION

Subject Name & Code:

Mechanical Measurement and Metrology- 3141901

Unit 1: Introduction to Metrology, Linear and Angular Measurement

Repeated Questions:

1. Define Metrology and list its objectives / Explain the role of measurement.

Appeared in: W25 (Q1a, 03 marks), S23 (Q1a, 03 marks)

Answer:

- **Metrology** is the science of measurement, encompassing both theoretical and practical aspects of measurement, including accuracy, precision, and standards.
- **Objectives:**
 - Ensure **accuracy** and **uniformity** of measurements.
 - Provide **traceability** to national/international standards.
 - Detect and minimize **measurement errors**.
 - Evaluate new instruments and **calibrate** existing ones.
 - Maintain **interchangeability** in manufacturing.
 - Reduce **inspection costs** and rejections.

(Highest weightage: 7 marks – add example: In automotive industry, metrology ensures engine parts fit correctly.)

2. Draw a block diagram of a generalized measurement system (GMS) and explain its elements.

Appeared in: W25 (Q1c, 07 marks), W24 (Q1b, 04 marks), W23 (Q2c, 07 marks), S25 (Q4c, 07 marks), S23 (Q2c, 07 marks), S22 (Q4c, 07 marks)

Answer:

- **Block Diagram** (text representation):
 [Input] → [Primary Sensing Element] → [Variable Conversion Element] →
 [Manipulation/Amplification] → [Data Transmission] → [Output/Display]
- **Elements:**

Element	Function	Example (Thermocouple thermometer)
Primary sensing element	Detects physical quantity	Thermocouple junction
Variable conversion element	Converts signal without changing information	Cold junction compensation
Manipulation/amplification	Amplifies/linearizes	Amplifier circuit

Element	Function	Example (Thermocouple thermometer)
	signal	
Data transmission	Sends signal to display	Wires / wireless
Output/display	Shows result	Digital display / pointer

- **[DG PROMPT]** Title: Generalized Measurement System Block Diagram.
Description: Draw five rectangular blocks in horizontal sequence with arrows between them. Label blocks: 1) Primary Sensing Element, 2) Variable Conversion Element, 3) Manipulation/Amplification, 4) Data Transmission, 5) Output/Display. Below each, add example: Thermocouple, Cold junction, Amplifier, Cable, Display.

3. Differentiate between Line Standards and End Standards.

Appeared in: W25 (Q2b, 04 marks), W23 (Q1b, 04 marks), W22 (Q5a, 03 marks)

Answer:

Parameter	Line Standards	End Standards
Definition	Length measured between two engraved lines	Length measured between two parallel flat faces
Example	Steel rule, measuring tape	Slip gauges, end bars
Accuracy	Moderate (0.1 mm to 0.5 mm)	High (0.0005 mm to 0.001 mm)
Wear effect	Lines do not wear easily	Faces wear with use
Ease of use	Direct reading	Requires wringing or stacking
Application	Rough measurements	Precision measurements in metrology labs

4. Explain wavelength standards.

Appeared in: W25 (Q1b, 04 marks)

Answer:

- **Principle:** Use monochromatic light wavelength as a natural, invariable standard of length.
- **Standard:** 1 metre = 1,650,763.73 wavelengths of orange-red radiation from **Krypton-86** (formerly) or now defined using speed of light.
- **Advantages:**

- Indestructible and reproducible anywhere.
- No wear or aging.
- Extremely high accuracy (parts per billion).
- **Disadvantages:** Requires sophisticated optical setup (interferometer).
- **Application:** Calibration of slip gauges, precision length measurement in laboratories.

○

5. Explain with a neat sketch the construction and working of an Auto Collimator. / Write a short note on Auto Collimator.

Appeared in: W25 (Q3c, 07 marks), W22 (Q1c, 07 marks), S25 (Q2c, 07 marks)

Answer:

- **Definition:** An autocollimator is an optical instrument used to measure small angular deviations (seconds of arc) by reflecting a collimated light beam off a mirror.
- **Construction:**
 - Light source (e.g., LED or lamp) at focal plane of a collimating lens.
 - Collimating lens produces parallel beam.
 - Beam splitter (or half-silvered mirror) directs beam toward external reflector.
 - Eyepiece with a reticle (crosshair or scale) for viewing the reflected image.
 - Micrometer eyepiece for precise measurement.
- **Working:**
 - Parallel light strikes a flat external reflector attached to the workpiece.
 - Reflected light returns through the same lens.
 - If reflector is tilted by angle θ , the returning beam is deflected by 2θ relative to the optical axis.
 - Deflected beam forms an image displaced from the reticle zero.
 - Displacement measured using micrometer eyepiece \rightarrow angular deviation = displacement / ($2 \times$ focal length).
- **Applications:** Checking flatness of machine tables, alignment of guideways, measuring small angles of polygons, calibration of rotary tables.
- **Why preferred over sine bar for $>45^\circ$?** No physical limit; works for any angle. More accurate for small angles.
- [DG]

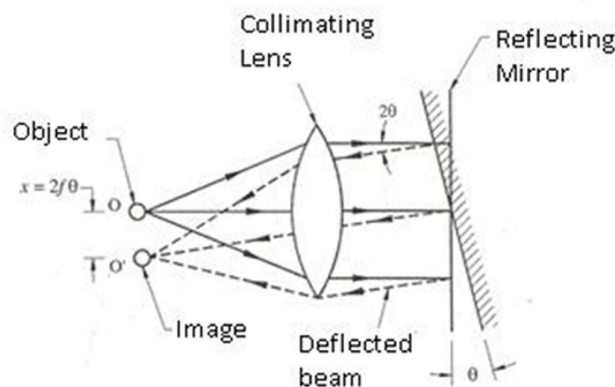

Fig.1.62 – Principle of auto-collimator

○

6. Explain the construction and working of a Vernier Height Gauge / Vernier Caliper.

Appeared in: W24 (Q1c, 07 marks), S22 (Q5c, 07 marks - Vernier Caliper)

Answer:• **Construction:**

- Vertical beam with main scale (mm/inches) mounted on heavy base.
- Slider with vernier scale moves along beam.
- Scriber (pointed tip) attached to slider for marking heights.
- Fine adjustment knob and locking screw.

• **Working principle:** Vernier principle – difference between main scale division (1 mm) and vernier scale division (0.98 mm for 0.02 mm least count).• **Use:** Measure heights of workpieces from surface plate, marking out lines at specific heights, checking step dimensions.• **Least count:**

For main scale 1 mm and vernier 50 divisions = 49 main divisions $\Rightarrow LC = 1 - (49/50) = 0.02$ mm.

• [DG]

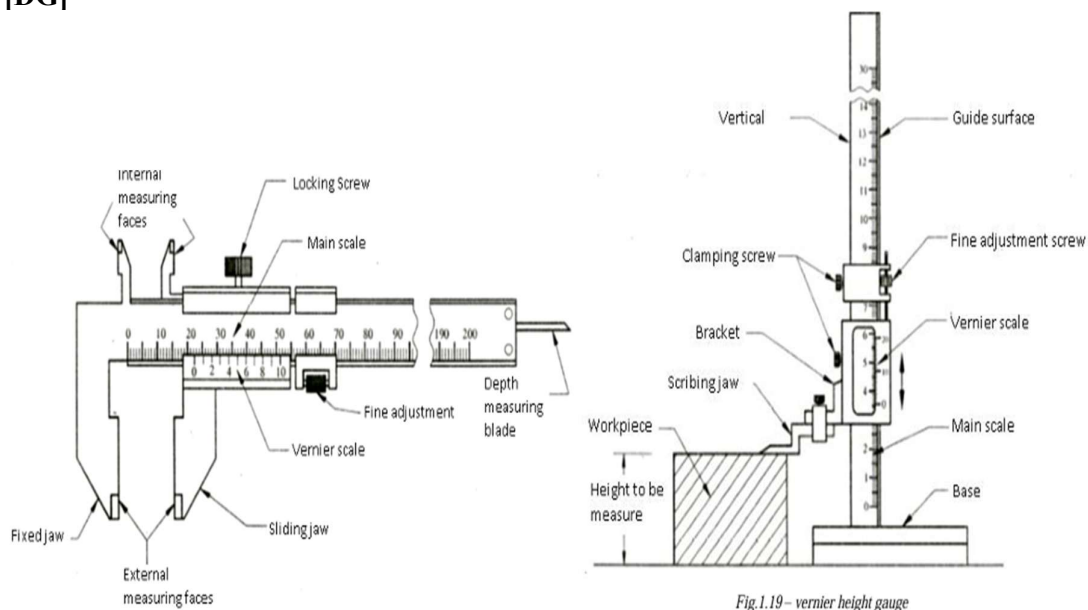

7. **What are Slip Gauges? Explain wringing and the manufacturing process of slip gauges. / Explain the role of Slip Gauges.**

Appeared in: W25 (Q4c, 07 marks), S23 (Q2b, 04 marks)

Answer:

- **Slip Gauges** (also called gauge blocks or Johansson blocks) are rectangular blocks of hardened steel/ceramic with two precisely parallel, flat surfaces used as length standards.

Wringing:

- Phenomenon where two slip gauges adhere tightly when slid together with a twisting motion.
- **Reason:** Molecular attraction + thin layer of oil/air exclusion + atmospheric pressure.
- Enables building of any dimension by stacking.

Manufacturing process:

1. **Material selection:** High-grade steel (1% C, Cr) or tungsten carbide.
2. **Rough machining:** Grinding to approximate size.
3. **Heat treatment:** Hardening + stabilization (aging).

4. **Lapping:** Superfinishing on cast iron plates using diamond paste.
 5. **Final lapping:** Achieves flatness $< 0.1 \mu\text{m}$ and parallelism $< 0.05 \mu\text{m}$.
 6. **Calibration:** Against master blocks by interferometry.
 - **Applications:** Calibration of micrometers, verniers, setting comparators, measuring precision parts.
-
8. **Explain the use of a Sine Bar for angle measurement with a neat sketch. / Write a short note on Sine Bar.**
 Appeared in: **W25 (Q4a, 03 marks), W23 (Q2c OR, 07 marks), S25 (Q2b, 04 marks), S23 (Q3c, 07 marks), S22 (Q2b, 04 marks - Diff. Sine bar & center)**

Answer:

- **Sine Bar** is a precision angle measuring instrument based on trigonometric sine principle.
- **Construction:**
 - Hardened steel bar with two precision rollers of equal diameter fixed at exact center distance (usually 100 mm, 200 mm, or 300 mm).
 - Top surface flat and parallel to roller axes.
- **Working principle:**

$$\sin \theta = \frac{h}{L}$$

where h = height of slip gauge stack under one roller, L = center distance between rollers.

- **Procedure:**
 1. Place sine bar on surface plate.
 2. Place workpiece on top.
 3. Calculate $h = L \times \sin \theta$ (θ = desired angle).
 4. Build slip gauge stack of height h under one roller.
 5. Workpiece top becomes inclined at angle θ .
 6. Check with dial indicator for flatness/parallelism.
- **[DG]**

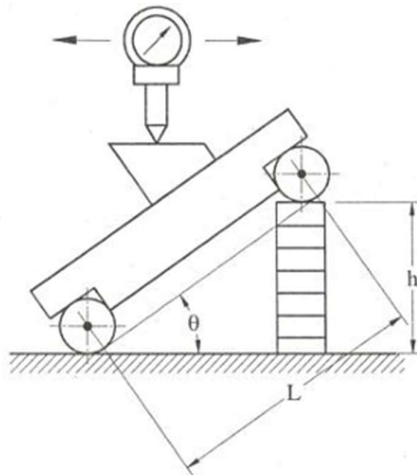

Fig.1.53 – Measuring angle of small size component

- **Why not preferred for $>45^\circ$:**
 For angles $>45^\circ$, the required h becomes $>0.707L$, making the setup unstable; also sine curve becomes less sensitive ($d\theta/dh$ decreases). **For $>45^\circ$, use angle gauges or**

autocollimator.

(Highest weightage: 7 marks – includes reason for angle limit)

○

Other Important Questions:**1. Define Accuracy, Precision, Repeatability, Resolution.**

Appeared in: W23 (Q1a, 03 marks), S25 (Q1b, 04 marks - Acc. & Prec.), S22 (Q1b, 04 marks - Acc., Prec., Reprod., Repeat.)

Answer:

Term	Definition	GTU Example
Accuracy	Closeness of a measured value to the true value .	A micrometer reads 10.02 mm when true length is 10.00 mm → low accuracy.
Precision	Closeness of repeated measurements to each other (scatter).	Five readings: 10.01, 10.02, 10.01, 10.02, 10.01 → high precision.
Repeatability	Ability of an instrument to give the same output for repeated applications of the same input under same conditions.	Same operator, same part, same gauge → variation within small range.
Resolution	The smallest change in input that causes a detectable change in output (smallest division on scale).	A vernier caliper with 0.02 mm resolution can distinguish 0.02 mm difference.

For 4 marks: Also mention **Reproducibility** – closeness of measurements under different conditions (different operator, different lab).

○

2. Compare/ Differentiate between Systematic and Random Errors.

Appeared in: W25 (Q5a, 03 marks), W24 (Q4a OR, 03 marks), S25 (Q1b, 04 marks)

Answer:

Parameter	Systematic Error	Random Error
Nature	Consistent, repeatable	Unpredictable, varies
Cause	Instrument calibration, environmental, method	Human, friction, vibrations
Pattern	Same magnitude and sign for repeated readings	Different magnitude and sign

Parameter	Systematic Error	Random Error
Detection	By comparing with standard	By statistical analysis
Correction	Possible by calibration	Only reduced by averaging
Example	Zero error in micrometer	Parallax error in scale reading

3. **List/types of errors in measurement. Discuss systematic errors in brief.**

Appeared in: W23 (Q1c, 07 marks), S23 (Q1c, 07 marks)

Answer:

Types of errors:

1. Gross errors (human mistakes)
2. Systematic errors (constant/ predictable)
3. Random errors (statistical scatter)

Systematic errors – further classified:

- **Instrumental errors:** due to calibration, wear, hysteresis, loading effect.
- **Environmental errors:** temperature, pressure, humidity, vibration.
- **Observational errors:** parallax, interpolation mistakes.
- **Method errors:** improper placement, alignment.

Brief discussion:

Systematic errors remain constant for all readings under same conditions. They shift the mean value away from true value. Can be identified and eliminated by calibration, using proper standards, or applying correction factors.

4. **Define Calibration, Hysteresis, Threshold.**

Appeared in: S25 (Q1a, 03 marks)

Answer:

- **Calibration:** Process of comparing an instrument's output with a known standard to determine accuracy and adjust for errors. Performed periodically for traceability.
- **Hysteresis:** Maximum difference in output for the same input when input is approached from opposite directions (increasing vs decreasing). Caused by mechanical play, magnetic effects.
- **Threshold:** The smallest change in input quantity that produces a detectable change in output. Below threshold, instrument does not respond.

5. **Define and explain: Sensitivity, Hysteresis, Range & Span, Accuracy & Precision.**

Appeared in: W24 (Q3b OR, 04 marks)

Answer:

Term	Definition	Explanation

Term	Definition	Explanation
Sensitivity	Ratio of change in output to change in input	$S = \frac{\Delta Output}{\Delta Input}$. High sensitivity means small input produces large output.
Hysteresis	Maximum output variation for same input from opposite directions	Caused by backlash, friction. Measured as % of full scale.
Range	Limits within which instrument can measure	e.g., 0–100°C.
Span	Algebraic difference between max and min range	e.g., Span = 100°C.
Accuracy	Closeness of measured value to true value	Expressed as % of full scale or % of reading.
Precision	Closeness of repeated measurements to each other	High precision \neq high accuracy (if systematic error present).

6. **Explain the various methods of measurement with examples.**

Appeared in: S25 (Q1c, 07 marks)

Answer:

1. **Direct measurement:**

- Value obtained directly from instrument.
- Example: Steel rule for length, spring balance for force.
- Simple but less accurate.

2. **Indirect measurement:**

- Measured quantity computed from other direct measurements.
- Example: Density = mass/volume (mass by balance, volume by displacement).
- Required when direct measurement not possible.

3. **Contact measurement:**

- Sensor touches the workpiece.
- Example: Micrometer, caliper, dial indicator.
- Risk of deformation or wear.

4. **Non-contact measurement:**

- No physical contact.
- Example: Optical pyrometer, laser interferometer, CMM with vision probe.
- Preferred for soft/hot/delicate parts.

5. **Deflection method:**

- Output proportional to measured quantity.
- Example: Pressure measured by Bourdon tube deflection.

6. **Null method:**

- Adjust a known quantity until zero output.

- Example: Wheatstone bridge for resistance, pressure balance for calibration.
- Higher accuracy.

7. **Comparison method:**

- Compare with known standard.
- Example: Slip gauges for length comparison, comparator.

○

7. **Discuss the factors relating to the selection of instruments.**

Appeared in: S22 (Q1a, 03 marks)

Answer:

Key factors:

- **Accuracy required:** Higher accuracy increases cost.
- **Range & span:** Must cover expected values.
- **Sensitivity:** Adequate for smallest change.
- **Environmental conditions:** Temperature, humidity, dust, vibration.
- **Dynamic response:** For rapidly varying signals.
- **Cost:** Initial + maintenance.
- **Ease of operation & reading:** Digital vs analog.
- **Reliability & ruggedness.**
- **Calibration traceability:** Availability of standards.
- **Non-contact capability:** For soft or moving parts.

○

8. **Define Transducer and Transfer Efficiency. Classify transducers in detail.**

Appeared in: S22 (Q1c, 07 marks)

Answer:

- **Transducer:** Device that converts one form of energy to another (usually physical quantity to electrical signal).
- **Transfer efficiency:** Ratio of output power to input power; in passive transducers, it's low; in active (self-generating), it's moderate.

Classification:

Basis	Types	Examples
Energy source	Active (self-generating)	Thermocouple, piezoelectric
	Passive (externally powered)	LVDT, strain gauge (Wheatstone bridge)
Output signal	Analog	Thermocouple mV, RTD resistance
	Digital	Encoder, digital pressure gauge
Operating principle	Resistive	Strain gauge, potentiometer

Basis	Types	Examples
	Inductive	LVDT, proximity sensor
	Capacitive	Pressure transducer
	Piezoelectric	Accelerometer
	Photoelectric	Photodiode, LDR
Application	Pressure, temperature, displacement, force, etc.	-

9. **Compare Primary, Secondary, and Working Standards. / Define and differentiate between primary, secondary, and working standards.**

Appeared in: W24 (Q1a, 03 marks), W22 (Q5a, 03 marks)

Answer:

Parameter	Primary Standard	Secondary Standard	Working Standard
Definition	Highest accuracy, maintained by national labs	Derived from primary, used in calibration labs	Used daily in industry
Accuracy	Highest (parts per billion)	Very high (ppm level)	Moderate (0.01–0.1%)
Calibration	Against natural constants (e.g., wavelength)	Against primary	Against secondary
Example	Krypton-86 light wavelength for meter	Reference slip gauge set	Workshop slip gauges
Frequency of use	Rare (once every few years)	Occasional	Daily

10. **Explain the sources of errors in a Micrometer.**

Appeared in: S22 (Q2a, 03 marks)

Answer:

- **Zero error:** Anvil and spindle not touching at zero reading (positive or negative).
- **Pitch error:** Inaccurate lead screw thread (cumulative over travel).

- **Parallax error:** Viewing angled from scale.
- **Wear:** On anvil faces or spindle threads.
- **Temperature effect:** Expansion of frame or workpiece.
- **Pressure error:** Over tightening the ratchet.
- **Cosine error:** Micrometer not aligned exactly parallel to measurement axis.

11. Describe the construction and working of a Vernier Micrometer with a neat sketch.

Appeared in: W24 (Q3a OR, 03 marks)

Answer:

- **Construction:** Combination of micrometer and vernier. Even with ordinary micrometer least count 0.01 mm, a vernier scale on the thimble sleeve gives LC = 0.001 mm (1 μ m).
- **Working:**
 - Thimble scale has 50 divisions (0.01 mm each).
 - Vernier scale engraved on sleeve has 10 divisions covering 9 thimble divisions.
 - $LC = 0.01 \times (1 - 9/10) = 0.001$ mm.
- **Sketch:**

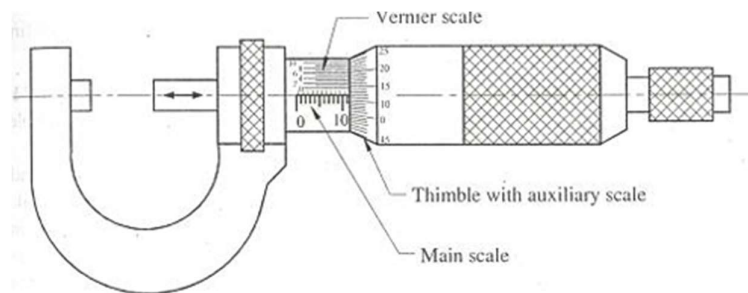

Fig.1.28 – Vernier micrometer

- **Application:** Precision measurement of thin parts, gauge blocks, wires.

12. Explain different Angular Measuring Instruments.

Appeared in: S23 (Q3a, 03 marks)

Answer:

1. **Bevel protractor** (least count 5 minutes): For angles up to 180°.
2. **Universal bevel protractor:** LC 5 min or 2 min, with acute angle attachment.
3. **Sine bar:** For accurate angles (10 sec to 1 min) using slip gauges.
4. **Autocollimator:** For small angular deviations (0.1 sec).
5. **Precision spirit level:** For slopes, small angles.
6. **Angle gauges:** Set of fixed angle blocks (e.g., 1°, 3°, 9°, 27°, 41°).

13. Enlist different types of measurement. / Classify measuring instruments.

Appeared in: S23 (Q2a, 03 marks)

Answer:

(classification of measuring instruments):

1. **By measuring method:**

- Direct reading (scale, micrometer)
- Comparison (comparator)
- 2. **By operation principle:**
 - Mechanical (vernier, micrometer)
 - Electrical (LVDT, strain gauge)
 - Electronic (digital gauges)
 - Optical (autocollimator)
- 3. **By function:**
 - Length measuring (scale, gauge blocks)
 - Angle measuring (sine bar, protractor)
 - Surface finish (profilometer)

○

14. **Explain the vernier principle.**

Appeared in: S22 (Q5c, 07 marks)

Answer:

- **Principle:** By having two scales – a fixed main scale and a movable vernier scale with slightly different division lengths – we can measure fractional parts of the main scale division.
- **Least count** = Value of 1 main scale division – Value of 1 vernier scale division.
- **Mathematically:**

$$LC = \frac{\text{Smallest main scale division}}{\text{Number of vernier divisions}}$$

Example: 1 mm / 50 = 0.02 mm.
- **Working:** When vernier zero coincides with a main division, the nth vernier division coinciding with a main division indicates $n \times LC$.

○

15. **State different types of linear measuring instruments.**

Appeared in: S23 (Q3b OR, 04 marks)

Answer:

1. **Non-precision instruments:** Steel rule, caliper, divider.
2. **Precision instruments:** Micrometer, vernier caliper, height gauge, depth gauge.
3. **Comparing instruments (comparators):** Dial indicator, sigma comparator, electrical comparator.
4. **Length standards:** Slip gauges (end standard), scale (line standard).
5. **Automated:** Digital caliper, laser interferometer, LVDT.

○

16. **What is the function of a Bevel Protractor?**

Appeared in: S23 (Q4b OR, 04 marks)

Answer:

- **Function:** To measure angles of workpieces accurately (± 5 minutes to ± 2 minutes).
- **Components:** Circular main scale (180°), adjustable blade, vernier scale, locking screws.
- **Working:** Place workpiece between blade and base; read angle from main + vernier.
- **Applications:** Tool angles (drill point, turning tool), taper angles, jig & fixture angles.

○
17. List the desirable characteristics of a measuring instrument (from context: good accuracy in sine bar).

Appeared in: W22 (Q4b, 04 marks)

Answer:

(characteristics of sine bar for good accuracy):

1. **Flatness:** Top surface must be perfectly flat.
2. **Parallelism:** Top surface parallel to roller axes within 0.002 mm.
3. **Equal roller diameters:** Within 0.0005 mm.
4. **Precise center distance (L):** Accurately known (e.g., 100 ± 0.003 mm).
5. **Hardness:** Rollers hardened to 60–65 HRC to resist wear.
6. **Corrosion resistance:** Nickel-chrome plated.

○
18. Define Joe Blocks and state the material used for its fabrication & its application.

Appeared in: W22 (Q2a, 03 marks)

Answer:

- **Definition:** Slip gauges or gauge blocks – precision length standards with two parallel measuring faces.
- **Material:** High carbon high chromium steel (hardened), tungsten carbide, ceramic (Zirconia).
- **Applications:**
 - Calibration of micrometers, verniers, comparators.
 - Setting sine bars for angle measurement.
 - Gap setting in assembly jigs.
 - Direct measurement of tolerances.

Q. Define: (any 03 terms from W24 Q1a, W22 Q5a) – sensitivity, linearity, calibration, etc. (3 marks)

Ans (example definitions):

- **Sensitivity:** Change in output per unit change in input. $S = \Delta O / \Delta I$.
- **Linearity:** Maximum deviation of calibration curve from a straight line, expressed as % of full scale.
- **Calibration:** Comparison of instrument output with a known standard to determine accuracy and adjust for errors.